

Charcoal Adsorber Housings Nowata C Series, High Flow Models

1. Features

Closed loop glycol and amine systems pick up solids, oils, dissolved hydrocarbons and well inhibitors from the natural gas stream, fouling the fluids and causing a loss in operating efficiency. Sludge buildup, foaming and fluid discoloration are indications that fouling has occurred. This can mean loss of glycol to the gas stream or total shutdown of the dehydration or sweetening process. A cartridge type fiber filter will remove the solid contaminants, but a charcoal bed is required to remove oils, dissolved hydrocarbons, well inhibitors and degradation compounds from the glycol or amine systems.

The Nowata C Series activated carbon canister type adsorber is designed to remove entrained hydrocarbons from glycol and amine streams which eliminates fouling and maintains operating efficiency.

Standard Design

- 1 and 2 Canister Models Also Available
- Standard Sizes: 4, 6, 10 and 14 Canister Models
- 4 Canister Model - 150 PSI Working Pressure
- Larger Models - 100 PSI Working Pressure
- Larger Sizes and Higher Pressure Models Available
- Bolted Closure for Fast, Easy Canister Replacement
- Convenience of Containerized Carbon Rather Than Bulk
- Buna O-Ring Standard, Other Seal Materials Available
- Glycol/Amine Flow Rates to 20 GPH
- Carbon Steel Construction Standard
- Epoxy Lined Carbon Steel Offered
- Stainless Steel Construction Available



2. Dimensional Information Chart for "C" Series

Model	Number of Canisters	Max Pressure ⁽¹⁾		Max Flow Rating GPM ⁽²⁾	Shipping Pounds	Weight Kilograms	A	B	C	D
		PSI	KGM/SQCM							
C4	4	150	10.5	5	740	336	66	12-3/4	12-1/2	4-1/2
C6	6	100	7	8	1100	500	82	26	58	20-1/2
C10	10	100	7	14	1550	700	87	32	60	22-1/2
C14	14	100	7	20	1800	815	87	36	60	22-1/2

Dimensions are in inches, except where noted. The following dimensions are approximate values and are not intended for piping specifications.

General Notes:

- (1) Maximum allowable non-shock pressure.
- (2) Recommended maximum flow rate of glycol or amine. For charcoal to operate properly, the velocity of the fluid through the media should be relatively low. Flow ratings are based on dwell time in the carbon rather than velocity induced pressure drop across the canister. Oversizing the filter will provide more efficient removal of contaminate.

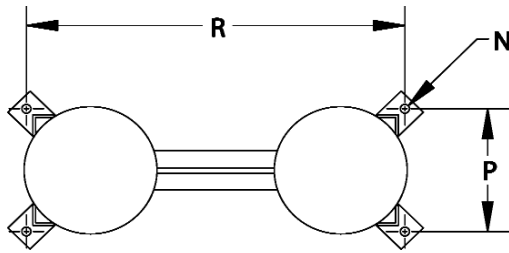

Typical Drawing
for Model Number:
C4 (4 Canister)

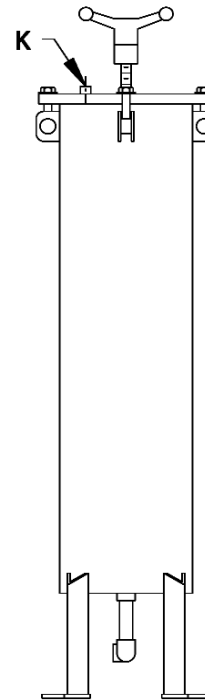
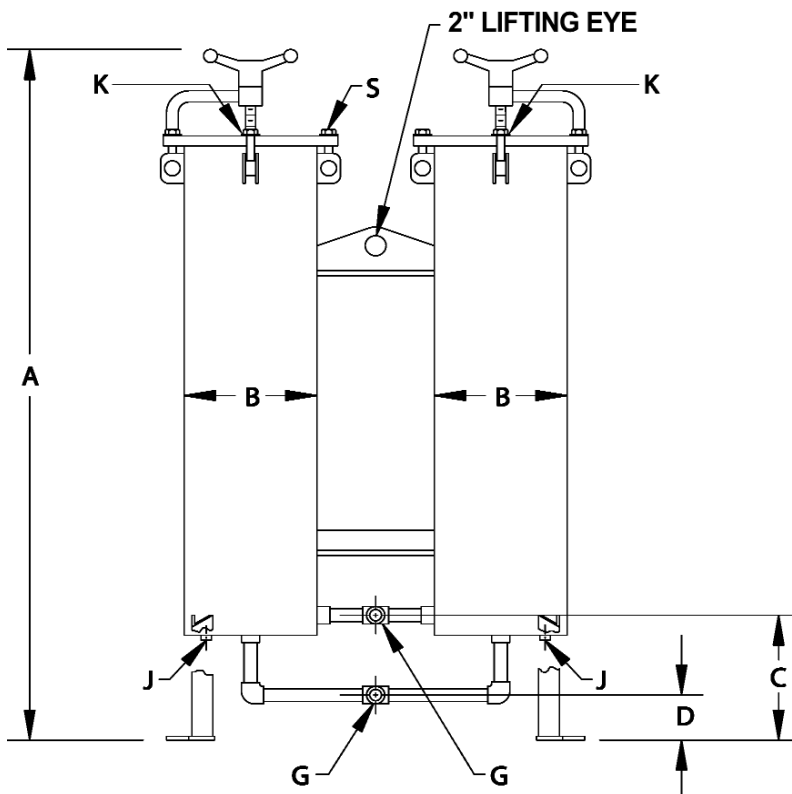

3. High Flow Charcoal Adsorbers

E	G	H	J	K	M	N	P	Q	R	S
--	1	--	1/2	1/4	--	(4 ea) 7/8	12-1/2	--	36-1/2	(8 ea) 3/4 NC
24-1/8	2	1	1	1/2	29-3/8	(8 ea) 7/8	6	30	--	(6 ea) 1 NC
26	2	1	1	1/2	35-3/8	(8 ea) 7/8	6	36	--	(6 ea) 1 NC
25-7/8	2	1	1	1/2	39-3/8	(8 ea) 7/8	6	40	--	(8 ea) 1 NC

Due to our continuing program of product improvement, dimensions are for reference only and subject to change without notice.

Dimensional Notes:

- | | | |
|---------------------------------------|---|---|
| A - Overall Height | H - Internal Pipe Thread Dirty Chamber Drain Size | N - Mounting Hole Quantity and Diameter |
| B - Vessel Diameter | J - Internal Pipe Thread Drain Size. | P - Mounting Hole Spacing |
| C - Height to Inlet Centerline | Note: Two Drains on the Model C4. | Q - Mounting Hole Circle Diameter |
| D - Height to Outlet Centerline | K - Internal Pipe Thread Vent Size. | R - C4 Mounting Hole Spacing |
| E - Height to Dirty Chamber Drain | Note: Two Vents on the Model C4. | S - Closure Bolt Quantity and Size |
| G - Inlet and Outlet Connection Size. | M - Inlet and Outlet Face to Face | |
| Internal Pipe Thread Standard. | | |

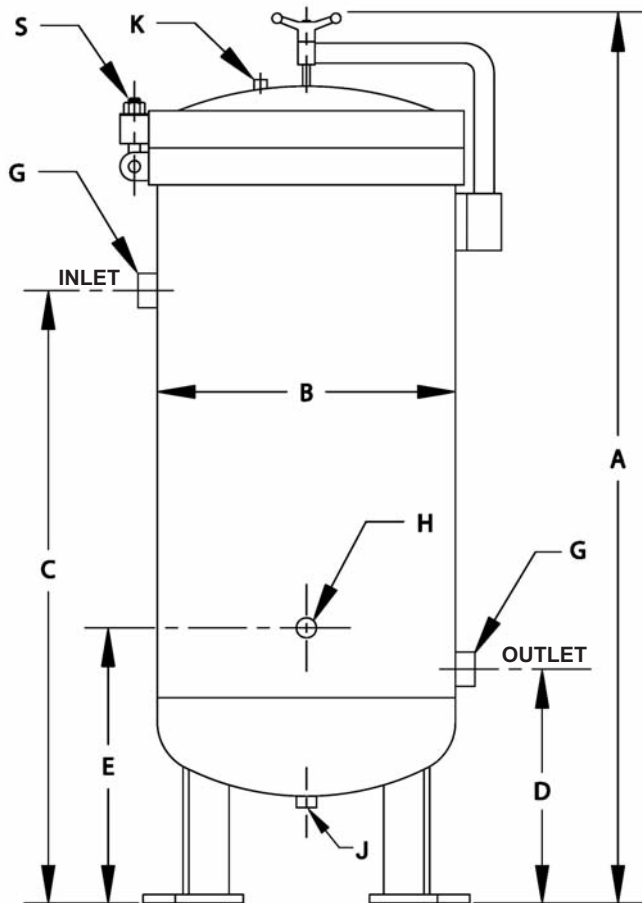

Typical Drawings for

Model Numbers:

C6 (6 Canister)

C10 (10 Canister)

C14 (14 Canister)

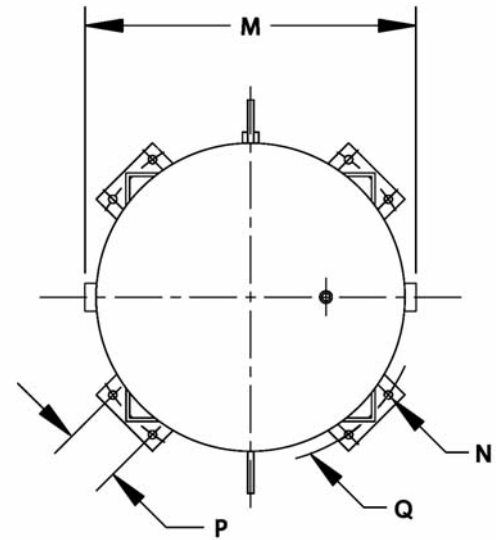

4. Standard Construction for Glycol and Amine

The Nowata High Flow rate "C" Series Charcoal Adsorbers are designed for low pressure charcoal treatment of glycol and amine in natural gas dehydrators and sweeteners. These units feature welded carbon steel construction with plated internal canister supports and retainers. The top closure utilizes bolting which is permanently attached to the vessel wall and swings away from the top during canister removal. The

closure seal is a Buna O-Ring. Standard inlet and outlet connections are 1" or 2" internal pipe thread, corresponding to the vessel size and number of canisters. All units are equipped with internal pipe thread vessel drain and vent. See the Dimension Information for the exact number of canisters each model holds, connection size, connection location and flow ratings.

5. Optional Construction

Materials of Construction

The Nowata "C" Series housings are constructed of all carbon steel with plated carbon steel internals. Post weld heat treatment (stress relieving) is available on special order for sour service. Epoxy lined carbon steel and stainless steel construction available on special order.

Seal Material

The Standard Buna O-Ring seal will operate to 220°F. Viton and Ethylene Propylene seals are available for special service. For best hydrocarbon removal efficiency, the operating temperature should be held below 120°F.

Connections

Inlet and outlet connections are available in sizes other than standard to fit customer requirements. Internal pipe thread drain and vent connections are provided as standard. ANSI flanges, external pipe thread, or non-standard sizes are available by special order. Special purpose connections such as relief valve fittings and pressure taps are available to meet a customer's specific requirements. Non-standard connection location, unusual mounting heights or dimensions are also available.

Special Pressure Ratings

The standard four canister housing is rated for a working pressure of 150 psi. Standard pressure rating of the larger housings is 100 psi. All Nowata "C" Series housings are designed with 1/32" corrosion allowance as standard. Special pressures and greater corrosion allowances are readily available.

Accessories

Several items are available to monitor or control filter operation. Differential pressure is not an indication that the carbon needs to be replaced. Therefore, a differential pressure gauge is not recommended for charcoal vessels. A pressure gauge, located in the vent connection, is an important safety device used to protect the operator from inadvertently opening the vessel closure under pressure. A vent valve should be installed to remove air trapped during canister replacement.

ASME Code Construction

The Nowata "C" Series filters are designed in accordance with the Boiler and Pressure Vessel Code of the American Society of Mechanical Engineers. When required, each unit can be stamped with the "U" symbol, denoting fabrication and testing performed by specific procedures.

6. Replacement Charcoal Canisters

The Nowata 11NC22 replacement charcoal canisters are 11" O.D. x 22" long. The granulated charcoal is held in place by a fabric outer sleeve just inside the perforated steel shell. The charcoal will not migrate downstream due to a micro-screen inner seal and perforated rigid metal core. Each cartridge has gasket end seals and a lifting handle for ease of replacement. The canister contains approximately 31 pounds of granulated charcoal. Charcoal adsorbers operate most

efficiently when the operating temperature is less than 120°F. Operation at a temperature greater than 220°F is not recommended. The Nowata Model 11NC22 replacement canisters are shipped in individual cardboard boxes which can be used for handling and disposal of spent canisters. The Nowata 11NC22 canister is a replacement for competitive activated charcoal elements that are 11" O.D. x 22" long.

MAHLE Industrial Filtration USA, Inc.
428 N. Elm, P.O.Box 678
Nowata, OK 74048 USA
Phone: 800-259-2204
Fax: 918-273-2101
mahle.nowata@us.mahle.com
www.nowata.com
6-2010