

Alkylation

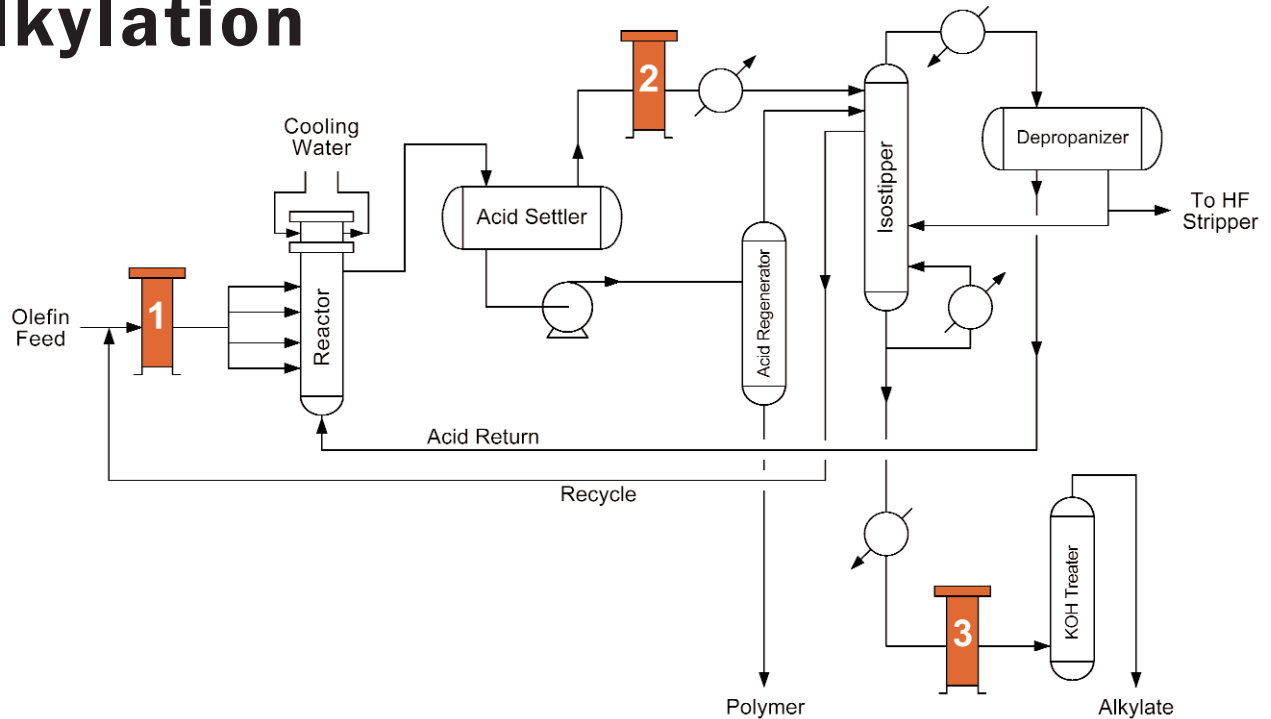

Alkylation processes catalytically combine C3 - C5 olefins with isobutene to produce high-octane branch chain hydrocarbon fuel additives that are used for producing clean-burning gasoline. In this process, the feedstocks are selectively hydrogenated and typically treated to remove sulfur and water contamination in order to reduce regeneration requirements, catalyst consumption and increase alkylate octane. The reactor system is designed for efficient contact and mixing of the feed with the acid catalyst.

Operational Problems

1. Reactor nozzle fouling
2. Solid contamination of treatment beds
3. Solid contamination of the alkylate

Solutions

1. A 10 micron Nowata Filtration pleated or depth type cartridge filter located on the inlet olefin feed will address the reactor nozzle-fouling problem.
2. A 25 micron Nowata Filtration pleated or depth type cartridge filter located after the acid settler on the alkylate intermediate prior to the isostripper / fractionator will remove any solids contamination created in the reaction or settling processes.
3. A 25 micron Nowata Filtration pleated or depth type cartridge filter on the alkylate from the isostripper / fractionator is installed before the KOH stripper to prevent plugging internals and to capture any carryover catalyst fines.