

# MAHLE

*Industrial Filtration*

## Bag Filter Housing for Liquids Nowata W8 Model

Available in Carbon or Stainless Steel for 15 or 30 Inch Deep Bags

### 1. Features

The Nowata W8 Model Liquid Bag Filter Vessel effectively removes dirt, pipe scale, and other contaminants from process liquids such as water, chemical and petroleum products. These housings can be used with the standard #1 or #2 Size Bags or the standard perforated basket as a strainer. This housing was designed for pressures up to 150 PSI with flow rates to 220 GPM. The housing comes standard in Carbon Steel or 316 Stainless Steel construction and FNPT or Flanged inlet and outlet.

#### Standard Design

- Housings in Carbon Steel or 316 Stainless Steel
- 150 PSI Working Pressure Rating
- Low Pressure Drop
- Hinged Quick-Opening Closure with Handle and Eye Nuts
- Differential, Drain and Vent Ports
- 316 Stainless Steel Strainer Basket
- Viton Lid Seal
- Adjustable Tripod Support Legs

#### Optional Features

- Mesh Lined Strainer Baskets
- ASME Code Stamp
- Higher Pressures Available
- Other Materials of Construction Available



NOWATA  
**N**  
PROGUARD

## 2. Standard Construction

The Nowata W8 Model Bag Housings are designed for operation up to 150 psi. The housing design provides a large sump area at the bottom of the basket for particulate accumulation. This design utilizes the filter more efficiently and prolongs the life of the bag filter. The 316 Stainless Steel basket rests on a steel support ring with an o-ring mounted in a groove, allowing the bag ring to seal and eliminate particulate bypass between the basket and ring. Optional mesh-lined strainer baskets and various materials for o-rings are available. A vent located in the housing

lid and a drain port allow fast evacuation and rapid filling. Gauge ports are located on the body of the housing to install gauges for monitoring of differential pressure across the bag or strainer basket. Permanently piped housings are opened with simple tools without disturbing the piping. Swing bolts with eye-nuts allow easy opening and closing of the swing-lid. There is no need to remove any hardware. As a standard finish, all vessels are blast cleaned and the outside of the vessel is painted with a coat of machinery enamel.

## 3. Dimensional Information

Pipe Size	Bag Depth	A	B	C	D	E	Basket Data for Nowata W8 Model Liquid Bag Vessel with Flow Rates to 220 gpm				
							Depth Nominal	Basket Diameter	Surface Area (sq. ft.)	Volume (cu. in.)	Standard Bag Size
2	15	5.3	6.7	24.7	25.4	1.0	15	6.7	2.3	500	# 1
2	30			36.2	37.4						
3	15	5.4	7.1	24.7	26.5	1.0	30	6.7	4.4	1000	# 2
3	30			36.2	38.0						
4	15	5.4	7.1	24.7	26.6	1.0	30	6.7	4.4	1000	# 2
4	30			36.2	38.1						

Dimensions shown in inches unless otherwise noted. Due to our continuing program of product improvement, specifications are for reference only and subject to change without notice. Dimensions are approximate values and not intended for piping specifications.

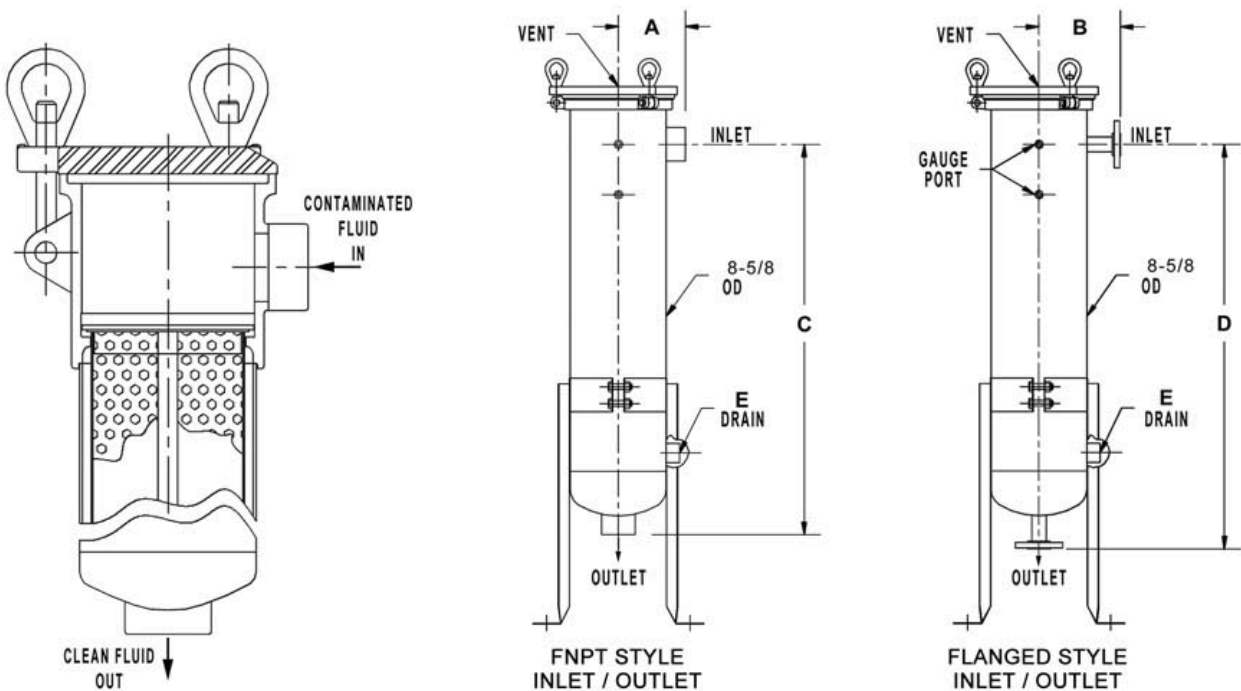

## 4. Typical Part Number

W	8	N	U	30	U	15	N	2
Bag Series	Vessel OD Inches	Inlet Location	Material	Basket Depth	ASME Code	Maximum Pressure	Inlet and Outlet Style	Inlet and Outlet Size

MAHLE Industrial Filtration USA Inc., 428 North Elm, P.O. Box 678, Nowata, OK 74048, Phone +1 800-259-2204, Fax +1 918-273-2101, mahle.nowata@us.mahle.com, www.nowata.com, www.mahle-industrialfiltration.com